

# The Fundamental Theorem of Algebra

## Bringing the Invisible To the Surface



*A Pedagogical Exercise in Two Parts, with an  
Afterword by Lyndon H. LaRouche, Jr.*

by Bruce Director

## I. Gauss's Declaration of Independence

In September 1798, after three years of self-directed study, Carl Friedrich Gauss, then 21 years old, left Göttingen University without a diploma, and returned to his native city of Brunswick to begin the composition of his *Disquisitiones Arithmeticae*. Lacking any prospect of employment, Gauss hoped to continue receiving his student stipend, without any assurance that his patron, Carl Wilhelm Ferdinand, Duke of Brunswick, would oblige. After several months of living on credit, word came from the Duke that the stipend would continue, provided

Gauss obtained his doctor of philosophy degree, a task Gauss thought a distraction, and wished to postpone.

Nevertheless, Gauss took the opportunity to produce a virtual declaration of independence from the stifling world of deductive mathematics, in the form of a written thesis submitted to the faculty of the University of Helmstedt, on a new proof of the fundamental theorem of algebra. Within months, he was granted his doctorate without even having to appear for oral examination.

Describing his intention to his former classmate, Wolfgang Bolyai, Gauss wrote, "The title [fundamental theorem] indicates quite definitely the purpose of the essay; only about a third of the whole, nevertheless, is used for this purpose; the remainder contains chiefly the history

---

*An earlier version of this article appeared in the April 12 and May 3, 2002, issues of Executive Intelligence Review (Vol. 29, Nos. 14 and 17).*

and a critique of works on the same subject by other mathematicians (viz. d'Alembert, Bougainville, Euler, de Foncenex, Lagrange, and the encyclopedists . . . which latter, however, will probably not be much pleased), besides many and varied comments on the shallowness which is so dominant in our present-day mathematics."

In essence, Gauss was defending, and extending, a principle that goes back to Plato, in which only physical action, not arbitrary assumptions, defines our notion of magnitude. Like Plato, Gauss recognized that it would be insufficient to simply state his discovery, unless it were combined with a polemical attack on the Aristotelean falsehoods that had become so popular among his contemporaries.

Looking back on his dissertation fifty years later, Gauss said, "The demonstration is presented using expressions borrowed from the geometry of position; for in this way, the greatest acuity and simplicity is obtained. Fundamentally, the essential content of the entire argument belongs to a higher domain, independent from space [i.e., anti-Euclidean-BD], in which abstract general concepts of magnitudes, are investigated as combinations of magnitudes connected by continuity: a domain, which, at present, is poorly developed, and in which one cannot move without the use of language borrowed from spatial images."

It is my intention to provide a summary sketch of the history of this idea, and Gauss's development of it. It can

not be exhaustive. Rather, it seeks to outline the steps which should form the basis for oral pedagogical dialogues, already underway in various locations.\*

## Multiply-Extended Magnitude

A physical concept of magnitude was already fully developed by circles associated with Plato, and expressed most explicitly in the *Meno*, *Theatetus*, and *Timaeus* dialogues. Plato and his circle demonstrated this concept, pedagogically, through the paradoxes that arise when considering the uniqueness of the five regular solids, and the related problems of doubling a line, square, and cube. As Plato emphasized, each species of action generated a different species of magnitude. He denoted such species by the Greek word *dunamis*, the root of the English "dynamo," usually translated into English as "power." The meaning of the term *dunamis* is akin to Leibniz's use of the German word *Kraft*.

That is, a linear magnitude has the "power" to double

\* This set of pedagogical exercises is part of an ongoing series on "Riemann for Anti-Dummies," produced for study by members and friends of the International Caucus of Labor Committees. Some have been published in *New Federalist* newspaper. See also Bruce Director, "The Division of the Circle and Gauss's Concept of the Complex Domain," *21st Century Science & Technology*, Winter 2001-2002 (Vol. 14, No. 14).



FIGURE 1. Doubling and "powers." (a) The magnitude which has the "power" to double the length of a line is produced by simple extension. (b) The magnitude which has the power to produce a square of double area, is the diagonal of the smaller square, and is called "the geometric mean" between the two squares. The magnitude of diagonal BC is incommensurable with, and cannot be produced by, the magnitude of side AB of the smaller square. (c) The magnitude which has the power to produce a cube of double volume, is different from the magnitudes which have the power to double a square, or a line. It is the smaller of two geometric means between the two cubes. This magnitude is incommensurable with both lower magnitudes, the square and the line.

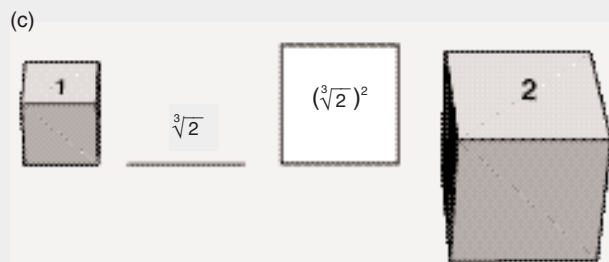
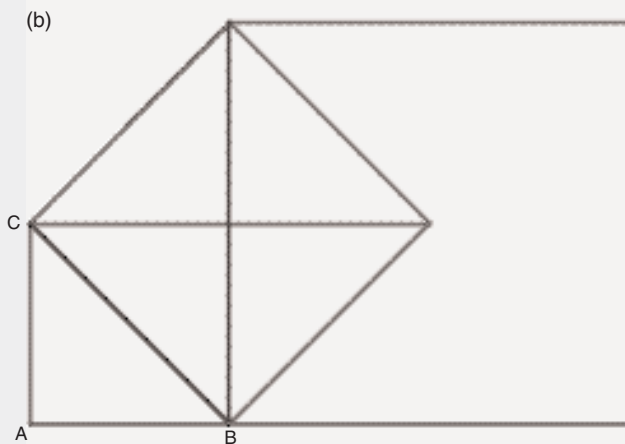

a line, whereas only a magnitude of a different species has the “power” to double a square, and a still different species has the “power” to double a cube [SEE Figure 1(a)-(c)]. In Bernhard Riemann’s terminology, these magnitudes are called, respectively: simply-extended, doubly-extended, and triply-extended. Plato’s circle emphasized that magnitudes of lesser extension lacked the potential to generate magnitudes of higher extension, creating, conceptually, a succession of “higher powers.”

Do not think here of the deductive use of the term “dimension.” While a perfectly good word, “dimension” in modern usage too often is associated with the Kantian idea of formal Euclidean space, in which space is considered as a combination of three, independent, simply-extended dimensions.

Think, instead, of “physical extension.” A line is produced by a physical action of simple extension. A surface may be bounded by lines, but it is not made from lines; rather, a surface is irreducibly doubly-extended. Similarly, a volume may be bounded by surfaces, which in turn are bounded by lines, but it is irreducibly triply-extended.

Thus, a unit line, square, or cube, may all be characterized by the number One, but each One is a species of a different power.

Plato’s circle also emphasized, that this succession of magnitudes of higher powers, was generated by a succession of differing types of action. Specifically, a simply-extended magnitude was produced from *linear action*, doubly-extended magnitudes from *circular action*, and triply-extended magnitudes from *extended circular action*, such as the rotational actions which pro-

duce a cone, cylinder, or torus. This is presented, pedagogically, by Plato in the *Meno* dialogue, with respect to doubly-extended magnitudes, and in the *Timaeus*, with respect to the uniqueness of the five regular solids, and the problem of doubling the cube. Plato’s collaborator, Archytas, demonstrated that the magnitude with which a cube is doubled, is not generated by circular action, but from extended circular action, i.e., conic sections [SEE Figure 2, and inside front cover, this issue].

It fell to Apollonius of Perga (262-200 B.C.) to present a full exposition of the generation of magnitudes of higher powers, in his work on *Conics*. His approach was to exhaustively investigate the generation of doubly- and triply-extended magnitudes, which he distinguished into plane (circle/line) and solid (ellipse, parabola, hyperbola) loci.

As Abraham Gotthelf Kästner indicates in his *History of Mathematics* (1797), the investigation of the relationships among higher powers, gave rise to what became known by the Arabic root word *algebra*; and, from Gottfried Wilhelm Leibniz (1644-1716) on, as *analysis*. Here, the relationship of magnitudes of the second power (squares) and the third power (cubes) were investigated in the form of, respectively, quadratic and cubic algebraic equations. Meanwhile, equations of higher than third degree took on a formal significance, but lacked the physical referent visible in quadratics and cubics.

Girolamo Cardan (1501-1576), and later, Leibniz, showed that there was a “hole” in the totality of forms of algebraic equations, as indicated by the appearance of the square roots of negative numbers as solutions to certain

FIGURE 2. Archytas’s construction for doubling of the cube. Archytas developed a construction to find two geometric means between two magnitudes, AC and AB. Magnitude AC is drawn as the diameter of circle ABC; AB is a chord of the circle. Using this circle as the base, generate a cylinder. The circle is then rotated 90° about AC, so it is perpendicular to the plane of circle ABC; it is then rotated about point A, to form a torus with nil diameter. (The intersection of the torus and the cylinder produces a curve of

double curvature.) Chord AB is extended until it intersects the perpendicular to AC at point D; this forms triangle ACD, which lies in plane of circle ABC, AB, and AC. Triangle ACD is then rotated around AC, producing a cone. The cone, torus, and cylinder, all intersect at point P. Perpendicular PM is then dropped from P along the surface of the cylinder, until it intersects circle ABC at point M; this forms right triangle AMP. Through this construction, a series of similar right triangles (only partially

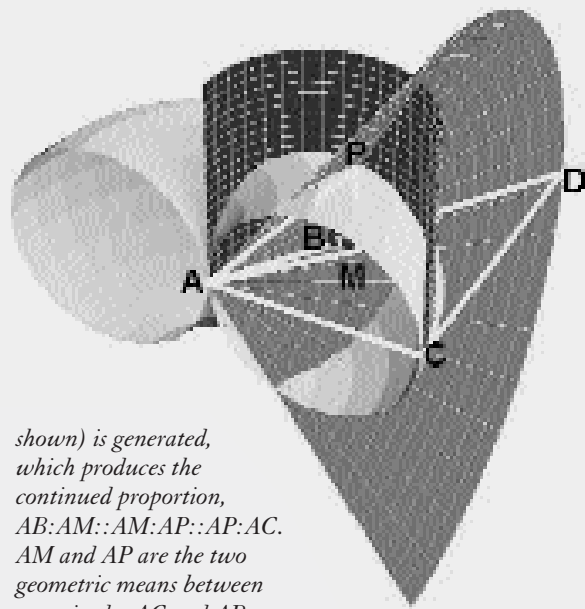

shown) is generated, which produces the continued proportion,  $AB:AM::AM:AP::AP:AC$ . AM and AP are the two geometric means between magnitudes AC and AB.

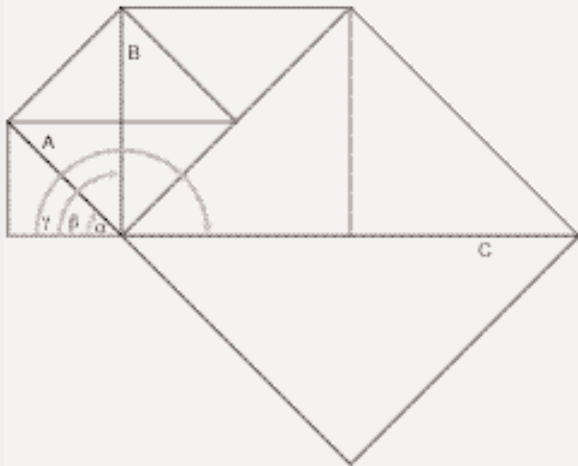

FIGURE 3. The principle of “squaring” involves doubling the angle of rotation and squaring the length. Angle  $\beta$  is double angle  $\alpha$ , and angle  $\gamma$  is double angle  $\beta$ . Also, the length of B is the square of A, and the length of C is the square of B.

equations. Peering into this “hole,” Leibniz recognized that algebra could teach nothing about physics; but, instead, that a general physical principle underlay all algebraic equations, of whatever power.

Writing in about 1675 to Christiaan Huyghens (1629-1695) on the square roots of negative numbers, Leibniz added that he had invented a machine which produced exactly the required action of this general physical principle:

It seems that after this instrument, there is almost nothing more to be desired for the use which algebra can or will be able to have in mechanics and in practice. It is believable that this was the aim of the geometry of the ancients (at least that of Apollonius) and the purpose of *loci* that he had introduced, because he had recognized that a few lines determine instantly, what long calculations in numbers could achieve only after long work capable of discouraging the most firm.

Although he determined the physical action that generated a succession of higher powers, Leibniz left open the question of what the physical action was, which produced the square roots of negative numbers.

## Gauss’s Proof of the Fundamental Theorem

By the time Gauss left Göttingen, he had already developed a concept of the physical reality of the square roots of negative numbers, which he called *complex numbers*.

Adopting the method of the metaphor of the cave from Plato’s *Republic*, Gauss understood his complex numbers to be shadows reflecting a complex of physical actions (action acting on action). This complex action reflected a power greater than the triply-extended action which characterizes the manifold of visible space.

It was Gauss’s unique contribution, to devise a metaphor by which to represent these higher forms of physical action, so that they could be represented, by their reflections, in the visible domain.

In his 1799 dissertation, Gauss brilliantly chose to develop his metaphor polemically, on the most vulnerable flank of his opponents’ algebraic equations. Like Leibniz, Gauss rejected the deductive approach of investigating algebraic equations on their own terms, insisting that it was physical action which determined the characteristics of the equations.

A simple example will help illustrate the point. Think of the physical meaning of the equation  $x^2=4$ . We all know that  $x$  refers to the side of a square whose area is 4. Thus, 2 is a solution to this equation. Now, think of the physical meaning of the equation  $x^2=-4$ . From a formal deductive standpoint, this equation refers to the side of a square whose area is -4. But, how can a square have a (negative) area of -4? Formally, the second equation can be solved by introducing the number  $2\sqrt{-1}$ , or  $2i$  (where  $i$  denotes  $\sqrt{-1}$ ), which, when squared, equals -4. But the question remains, what is the physical meaning of  $\sqrt{-1}$ ?

One answer is to say that  $\sqrt{-1}$  has no physical meaning, and thus the equation  $x^2=-4$  has no solution. To this, Euler and Lagrange added the sophistry, richly ridiculed by Gauss in his dissertation, that the equation  $x^2=-4$  has a solution, but the solution is impossible!

Gauss demonstrated the physical meaning of the  $\sqrt{-1}$ , not in the visible domain of squares, but in the *cognitive* domain of the *principle* of squaring.

This can be illustrated pedagogically, by drawing a square, whose area we will call 1. Then, draw diagonal  $A$  of that square, and draw a new square, using that diagonal as a side. The area of the new square will be 2. Now, repeat this action, to generate a square, whose area is 4 [SEE Figure 3].

What is the principle of squaring illustrated here? The action that generated the magnitude which produced the square whose area is 2, was a rotation of  $45^\circ$  and an extension of length from 1, the side of the first square, to  $\sqrt{2}$ , its diagonal, which becomes the side of the next square. To produce the square whose area is 4, the  $45^\circ$  rotation was doubled to  $90^\circ$ , and the extension was squared to become 2. Repeat this process several times, to illustrate that the principle of squaring can be thought of

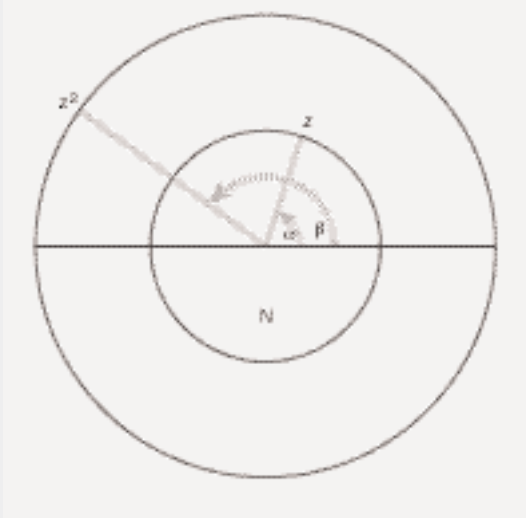

FIGURE 4. *Squaring a complex number. The general principle of “squaring” can be carried out on a circle.  $z^2$  is produced from  $z$  by doubling the angle  $\alpha$  and squaring the distance from the center of the circle to  $z$ .*

as the combined physical action of doubling a rotation, and squaring a length. The square root is simply the reverse action, that is, halving the angle of rotation, and decreasing the length by the square root.

Now, draw circle N and a diameter, and apply this physical action of squaring to every point on the circle. That is, take any point on the circumference of the circle (point  $z$  in the figure). Draw the radius connecting that point to the center of the circle. That radius makes an angle with the diameter you drew. To “square” that point, double angle  $\alpha$  between the radius and the diameter to form angle  $\beta$ , and square the length. Repeat this action with several points. Soon you will be able to see that all the points on the first circle map to points on a larger, concentric circle, whose radius is the square of the radius of the original circle. But, it gets curiously and curiously. Since you double the angle each time you square a point, the original circle will map onto the “squared” circle twice [SEE Figure 4].

There is a physical example that illustrates this process. Take a bar magnet and rotate a compass around the magnet. As the compass moves from the North to the South pole of the magnet ( $180^\circ$ ), the compass needle will make one complete revolution ( $360^\circ$ ). As it moves from the South pole back to the North, the needle will make another complete revolution. In effect, the bar magnet “squares” the compass!

Gauss associated his complex numbers with this type of compound physical action (rotation combined with extension). He made them visible, metaphorically, as spi-

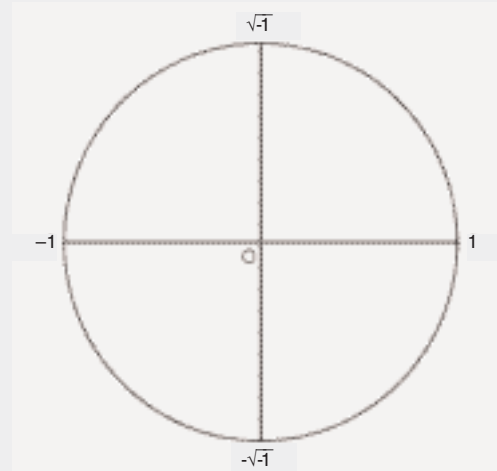

FIGURE 5. *The unit of action in Gauss's complex domain.*

ral action projected onto a surface. Every point on that surface represents a complex number. Each number denotes a unique combination of rotation and extension. The point of origin of the action ultimately refers to a physical singularity, such as the lowest point of the catenary, or the poles of the rotating Earth, or the center of the bar magnet.

Using the above example, consider the original circle to be a unit circle in the complex domain. The center of the circle is the origin, denoted by O, the ends of the diameter are denoted by 1 and -1. The square root of -1 is found by halving the rotation between 1 and -1, and reducing the radius by the square root. Think carefully, and you will see that  $\sqrt{-1}$  and  $-\sqrt{-1}$  are represented by the points on the circumference which are half-way between 1 and -1 [SEE Figure 5].

Gauss demonstrated that all algebraic powers, of any degree, when projected onto his complex domain, could be represented by an action similar to that just demonstrated for squaring. For example, the action of cubing a complex number is accomplished by tripling the angle of rotation and cubing the length. This maps the original circle three times onto a circle whose radius is the cube of the original circle. The action associated with the bi-quadratic power (fourth degree), involves quadrupling the angle of rotation and squaring the square of the length. This will map the original circle four times onto a circle whose radius is increased by the square of the square, and so forth for the all higher powers.

Thus, even though the manifolds of action associated with these higher powers exist outside the triply-extended manifold of visible space, the characteristic of action which produces them was brought into view by Gauss in his complex domain.

## II. Bringing the Invisible to the Surface

When Carl Friedrich Gauss, writing to Wolfgang Bolyai in 1798, criticized the state of contemporary mathematics for its “shallowness,” he was speaking literally; and not only about his time, but also ours. Then, as now, it had become popular for the academics to ignore, and even ridicule, any effort to search for universal physical principles, restricting instead the province of scientific inquiry to the seemingly more practical task, of describing only what is visible on the surface. Ironically, as Gauss demonstrated in his 1799 doctoral dissertation on the fundamental theorem of algebra, what’s on the surface is revealed, only if one knows what’s underneath.

Gauss’s method was an ancient one, made famous in Plato’s metaphor of the cave, and given new potency by Johannes Kepler’s application of Nicolaus of Cusa’s method of *Learned Ignorance*. For them, the task of the scientist was to bring into view the underlying physical principles, which can not be viewed directly—the unseen that guided the seen.

Take the illustrative case of Fermat’s discovery of the principle, that refracted light follows the path of least time, rather than the path of least distance followed by reflected light. The principle of least distance is one that lies on the surface, and can be demonstrated in the visible domain. On the other hand, the principle of least time exists “behind,” so to speak, the visible; it is brought into view only in the mind. On further reflection, it is clear that the principle of least time was there all along, controlling, invisibly, the principle of least distance. In Plato’s terms of reference, the principle of least time is of a “higher power” than the principle of least distance.

Fermat’s discovery is a useful reference point for grasping Gauss’s concept of the complex domain. As Gauss himself stated unequivocally, the complex domain does not mean the formal, superficial concept of “impossible” or imaginary numbers, as developed by Euler and taught by “experts” ever since. Rather, Gauss’s concept of the complex domain, like Fermat’s principle of least time, brings to the surface a principle that was there all along, but hidden from view.

### The Algebraic and the Transcendental

As Gauss emphasized in his jubilee re-working of his 1799 dissertation, the concept of the complex domain is a “higher domain,” independent of all *a priori* concepts of space. Yet, it is a domain “in which one cannot move without the use of language borrowed from spatial images.”

The issue for him, as for Gottfried Leibniz, was to find a general principle that characterized what had become known as “algebraic” magnitudes. These magnitudes, associated initially with the extension of lines, squares, and cubes, all fell under Plato’s concept of *dunamis*, or *power*.

Leibniz had shown, that while the domain of all “algebraic” magnitudes consisted of a succession of higher powers, this entire algebraic domain was itself dominated by a domain of a still higher power, which Leibniz called “transcendental.” The relationship of the lower domain of algebraic magnitudes, to the higher, non-algebraic domain of transcendental magnitudes, is reflected in what Jakob Bernoulli discovered about the equi-angular spiral [SEE Figure 6].

Leibniz, with Jakob’s brother Johann Bernoulli, subsequently demonstrated that this higher, transcendental domain does not exist as a purely abstract principle, but originates in the physical action of a hanging chain, whose geometric shape Christiaan Huyghens called a *catenary* [SEE Figure 7]. Thus, the physical universe itself demonstrates that the “algebraic” magnitudes associated with extension, are not *generated* by extension. Rather, the algebraic magnitudes are generated from a physical principle that exists beyond simple extension, in the higher, transcendental domain.

Gauss, in his proofs of the fundamental theorem of algebra, showed that even though this transcendental physical principle was outside the domain of the visible, it nevertheless “cast a shadow” which could be

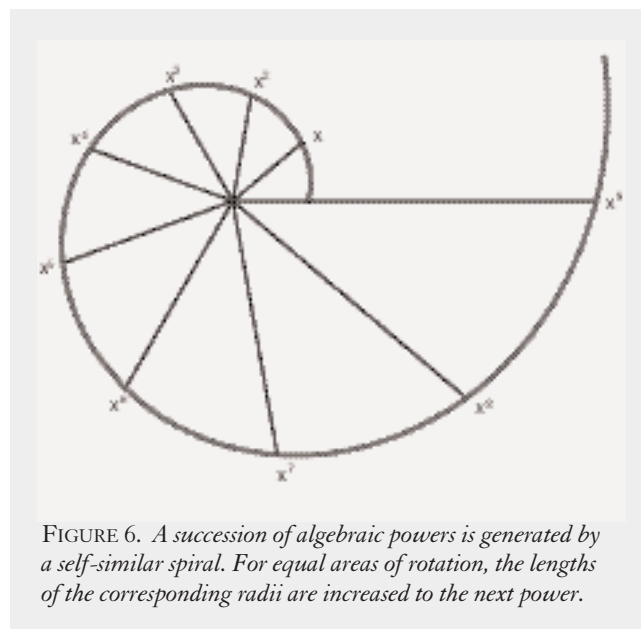

FIGURE 6. A succession of algebraic powers is generated by a self-similar spiral. For equal areas of rotation, the lengths of the corresponding radii are increased to the next power.

made visible in what Gauss called the complex domain.

As indicated in Part I, the discovery of a general principle for algebraic magnitudes was found, by looking through the “hole” represented by the square roots of negative numbers. These square roots appeared as solutions to algebraic equations, but lacked any apparent physical meaning. For example, in the algebraic equation  $x^2=4$ ,  $x$  signifies the side of a square whose area is 4; whereas, in the equation  $x^2=-4$ ,  $x$  signifies the side of a square whose area is -4, an apparent impossibility.

For the first case, it is simple to see that a line whose length is 2, would be the side of the square whose area is 4. However, from the standpoint of the algebraic equa-

tion, a line whose length is -2, also produces the desired square of area 4. At first glance, a line whose length is -2 seems as impossible as a square whose area is -4. Yet, if you draw a square of area 2, you will see that there are two diagonals, both of which have the power to produce a new square whose area is 4. These two magnitudes are distinguished from one another only by their direction, so one is denoted as 2, and the other as -2.

Now, extend this investigation to the cube. In the algebraic equation  $x^3=8$ , there appears to be only one number, 2, which satisfies the equation, and this number signifies the length of the edge of a cube whose volume is 8. This appears to be the only solution to this equation, since  $(-2)(-2)(-2)=-8$ , another seeming impos-

FIGURE 7. Leibniz's construction of the algebraic powers from the hanging chain, or catenary curve.

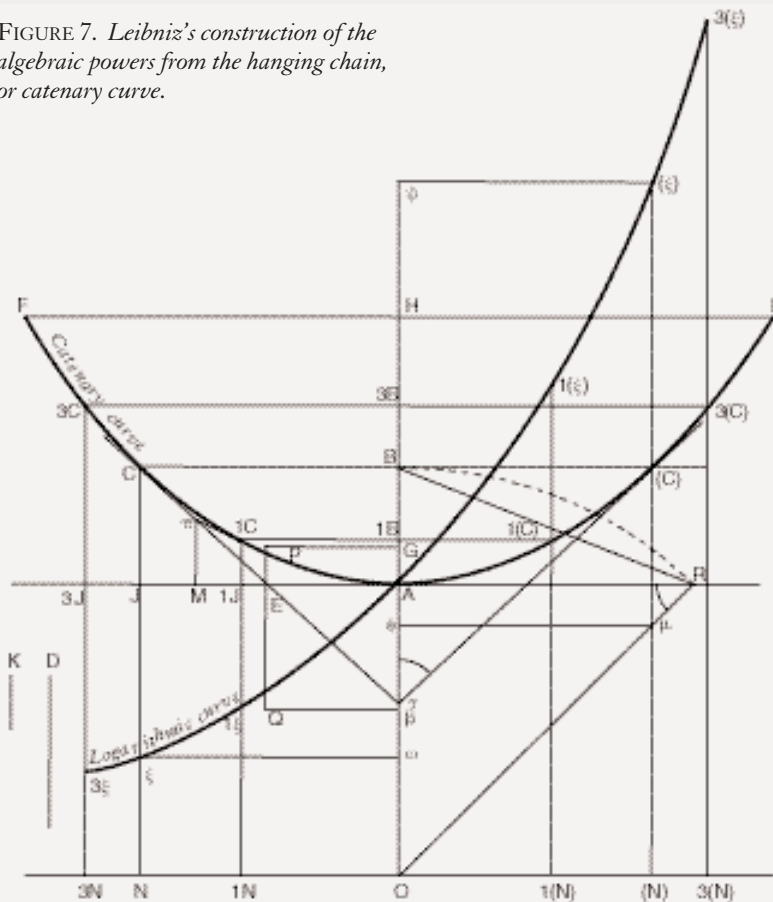

identify as logarithmic. So, by taking ON and O(N) as equal, elevate over N and (N) the segments NC and (N)(C) equal to the semi-sum of Nξ and (N)(ξ), such that C and (C) will be two points of the catenary curve FCA(C)L, on which you can determine geometrically as many points as you wish.

“Conversely, if the catenary curve is physically constructed, by suspending a string, or a chain, you can construct from it as many proportional means as you wish, and find the logarithms of numbers, or the numbers of logarithms. If you are looking for the logarithm of number Oω, that is to say, the logarithm of the ratio between OA and Oω, the one of OA (which I choose as the unit, and which I will also call parameter) being considered equal to zero, you must take the third proportional Oψ from Oω and OA; then, choose the abscissa as the semi-sum of OB from Oω and Oψ, the corresponding ordinate BC or ON on the catenary will be the sought-for logarithm corresponding to the proposed number. And reciprocally, if the logarithm ON is given, you must take the double of the vertical segment NC dropped from the catenary, and cut it into two segments whose proportional mean should be equal to OA, which is the given unity (it is child’s play); the two segments will be the sought-for numbers, one larger, the other smaller, than 1, corresponding to the proposed logarithm.”

—from G.W. Leibniz, “Two Papers on the Catenary Curve and Logarithmic Curve,” from “Acta Eruditorum” (1691) [Fidelio, Spring 2001 (Vol X, No. 1)].

“Given an indefinite straight line ON parallel to the horizon, given also OA, a perpendicular segment equal to O3N, and on top of 3N, a vertical segment 3N3ξ which has with OA the ratio of D to K, find the proportional mean 1N1ξ (between OA and 3N3ξ); then, between 1N1ξ and 3N3ξ then, in turn, find the proportional mean between 1N1ξ and

OA; as we go on looking for second proportional means in this way, and from them third proportionals, follow the curve 3ξ-1ξ-A-1(ξ)-3(ξ) in such a way that when you take the equal intervals 3N1N, 1NO, O1(N), 1(N)3(N), etc., the ordinates 3N3ξ, 1N1ξ, OA, 1(N)1(ξ), 3(N)3(ξ), are in a continuous geometric progression, touching the curve I usually

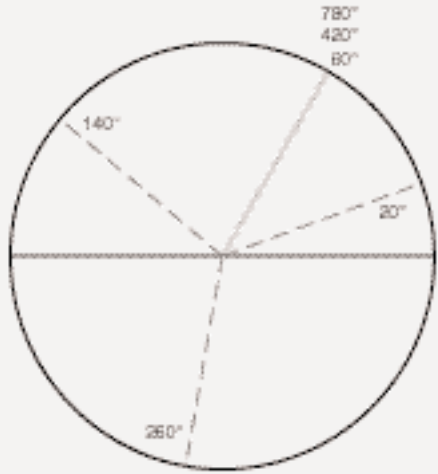

FIGURE 8 *An example of the three solutions to the trisection of an angle.*

sibility. The anomaly, that there are two solutions in the case of a quadratic equation, seems to disappear in the case of the cube, for which there appears to be only one solution.

### Trisecting an Angle

But, not so fast. Look at another geometrical problem which, when stated in algebraic terms, poses the same paradox: the trisection of an arbitrary angle. Like the dou-

bling of the cube, Greek geometers could not find a means for trisecting an arbitrary angle, from the principle of circular action itself. The several methods discovered (by Archimedes, Eratosthenes, and others) to find a general principle of trisecting an angle, were similar to those found by Plato's collaborators, for doubling the cube. That is, this magnitude could not be constructed using only a circle and a straight line, but it required the use of extended circular action, such as conical action. But, trisecting an arbitrary angle presents another type of paradox which is not so evident in the problem of doubling the cube. To illustrate this, perform the following experiment:

Draw a circle [SEE Figure 8]. For ease of illustration, mark off an angle of  $60^\circ$ . It is clear that an angle of  $20^\circ$  will trisect this angle. Now add an entire circular rotation to the  $60^\circ$  angle, making an angle of  $420^\circ$ . It appears these two angles,  $60^\circ$  and  $420^\circ$ , are essentially the same. But, when  $420^\circ$  is divided by 3, we get an angle of  $140^\circ$ . Add another  $360^\circ$  rotation, and we get to the angle of  $780^\circ$ , which appears to be exactly the same as the angles of  $60^\circ$  and  $420^\circ$ . Yet, when we divide  $780^\circ$  by 3 we get  $260^\circ$ . Keep this up, and you will see that the same pattern is repeated over and over again.

Looked at as a "sense certainty," the  $60^\circ$  angle can be trisected by only one angle, the  $20^\circ$  angle. Yet, when looked at beyond sense certainty, there are clearly three angles that "solve" the problem.

This illustrates another "hole" in the algebraic determination of magnitude. In the case of quadratic equations, there seem to be two solutions to each problem. In some cases, such as  $x^2=4$ , those solutions seem to have a

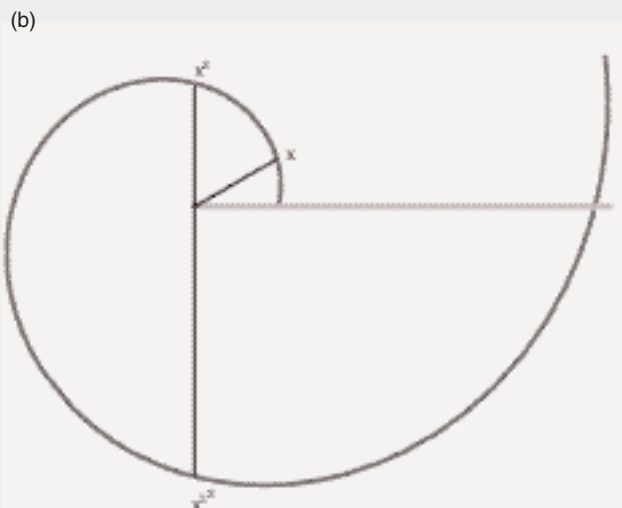
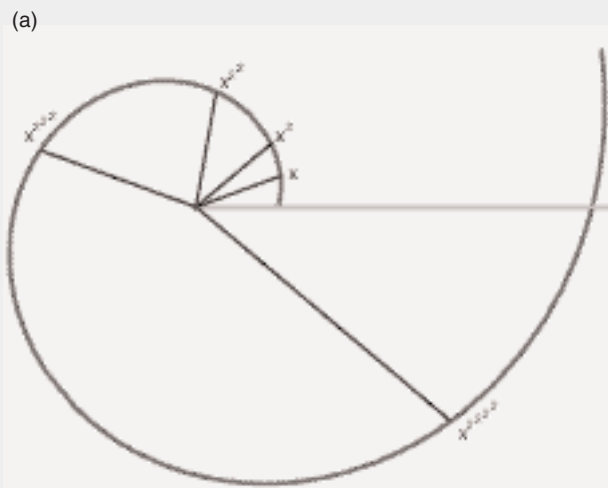

FIGURE 9. *In (a), the lengths of the radii are squared as the angle of rotation doubles. In (b), the lengths of the radii are cubed as the angle of rotation triples.*



visible existence; whereas for the case  $x^2=-4$ , there are two solutions,  $2\sqrt{-1}$  and  $-2\sqrt{-1}$ , both of which seem to be “imaginary,” having no physical meaning. In the case of cubic equations, sometimes there are three visible solutions, such as in the case of trisecting an angle. But in the case of doubling the cube, there appears to be only one visible solution, but two “imaginary” solutions:  $-1 - (\sqrt{3})(\sqrt{-1})$ ; and  $-1 + (\sqrt{3})(\sqrt{-1})$ .

Bi-quadratic equations, such as  $x^4=16$ , which seem to have no visible meaning themselves, have four solutions, two “real” (2 and -2) and two “imaginary” ( $2\sqrt{-1}$  and  $-2\sqrt{-1}$ ).

Things get even more confused for algebraic magnitudes of still higher powers. This anomaly poses the question resolved by Gauss in his proof of what he called the “fundamental theorem” of algebra: *How many solutions are there for any given algebraic equation?*

The “shallow”-minded mathematicians of Gauss’s day, such as Euler, Lagrange, and D’Alembert, took the superficial approach of answering, that an algebraic equation will have as many solutions as it has powers, even though some of those solutions might be “impossible,” such as the square roots of negative numbers. (This sophist’s argument is analogous to saying, “There is a difference between man and beast; but this difference is meaningless.”)

## Shadows of Shadows: The Complex Domain

Gauss, in his 1799 dissertation, polemically exposed this fraud for the sophistry it was: “If someone would say a rectilinear equilateral right triangle is impossible, there will be nobody to deny that. But, if he intended to consider such an impossible triangle as a new species of triangles and to apply to it other qualities of triangles, would anyone refrain from laughing? That would be playing with words, or rather, misusing them.”

For Gauss, no magnitude could be admitted, unless its principle of generation were demonstrated. For magnitudes associated with the square roots of negative numbers, that principle was the complex physical action of *rotation combined with extension*. Gauss called the magnitudes generated by this complex action, “complex numbers.” Each complex number denoted a quantity of combined rotational and extended action.

The unit of action in Gauss’s complex domain is a circle, which is one rotation, with an extension of one (unit length). In this domain, the number 1 signifies one complete rotation;  $-1$ , half a rotation;  $\sqrt{-1}$ , one-fourth of a rotation; and  $-\sqrt{-1}$ , three-fourths of a rotation [Figure 5].

These “shadows of shadows,” as he called them, were

only a visible reflection of a still higher type of action, which was independent of all visible concepts of space. These higher forms of action, although invisible, could nevertheless be brought into view as a projection onto a surface.

Gauss’s approach is consistent with that employed by the circles of Plato’s Academy. In ancient Greek, the word for surface, *epiphaneia* (it is the root of the English word “epiphany”), can be understood to mean the concept, “that on which something is brought into view.”

From this standpoint, Gauss demonstrated, in his 1799 dissertation, that the fundamental principle of generation of any algebraic equation, of no matter what power, could be brought into view, “epiphanied,” so to speak, as a surface in the complex domain. These surfaces were visible representations not—as in the cases of lines, squares, and cubes—of what the powers produced, but of the *principle* that produced the powers.

To construct these surfaces, Gauss went outside the simple visible representation of powers—such as squares and cubes—by seeking a more general form of powers, as exhibited in the equi-angular spiral [SEE Figure 9]. Here, the generation of a power, corresponds to the extension produced by an angular change. The generation of square powers, for example, corresponds to the extension that results from a doubling of the angle of rotation, within the spiral [Figure 9(a)]; and the generation of cubed powers corresponds to the extension that results from tripling the angle of rotation, within that spiral [Figure 9(b)]. Thus, it is the *principle of squaring* that produces square magnitudes, and the *principle of cubing* that produces cubics.

In Figure 10, the complex number  $z$  is “squared” when the angle of rotation is doubled from  $x$  to  $2x$ , and the length squared from  $A$  to  $A^2$ . In doing this, the smaller circle maps twice onto the larger, “squared” circle, as

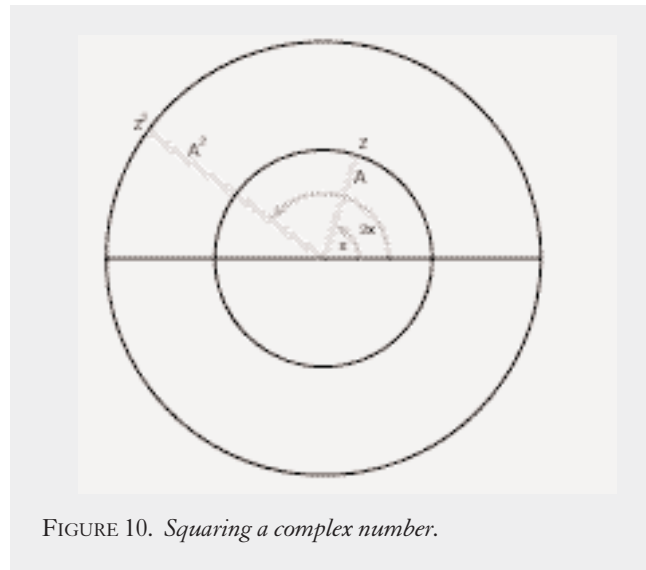

FIGURE 10. *Squaring a complex number.*

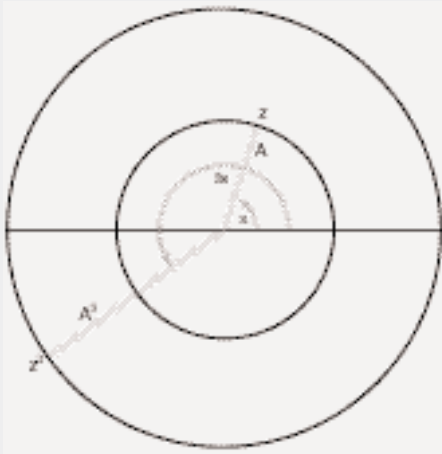

FIGURE 11. *Cubing a complex number.*

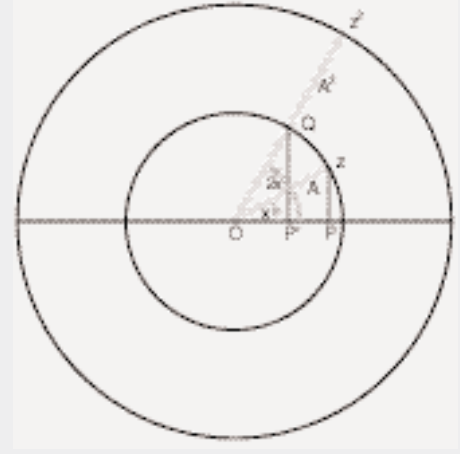
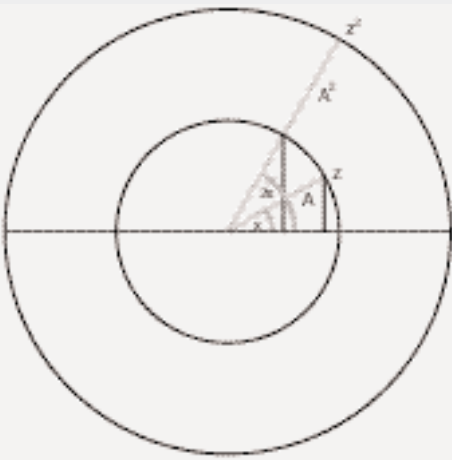

FIGURE 12. *The sine of angle  $x$  is the line  $Pz$ , and the cosine of  $x$  is  $OP$ . The sine of  $2x$  is the line  $P'Q$ , and the cosine is  $OP'$ .*

FIGURE 13. *Variations of the sine and cosine from the squaring of a complex number, for four quadrants, as angle  $x$  rotates from  $0^\circ$  to  $360^\circ$ .*

(a)



(b)

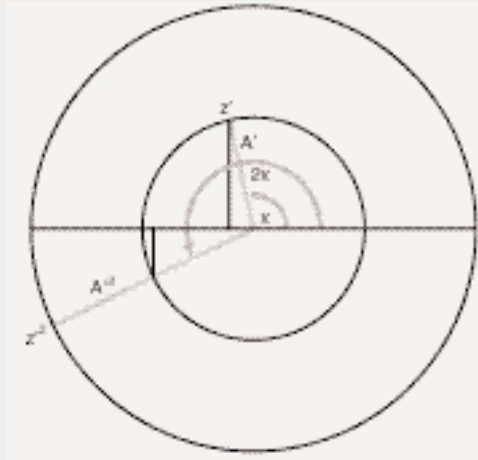

(c)

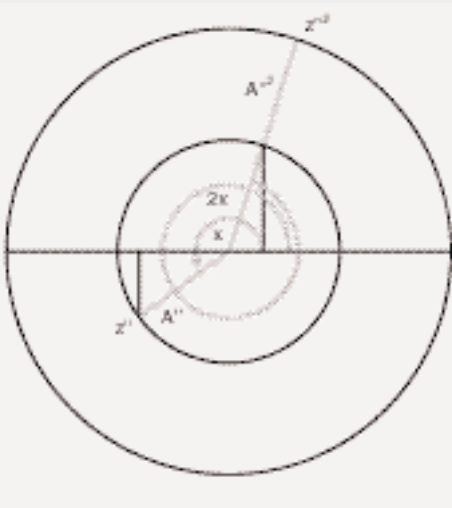

(d)

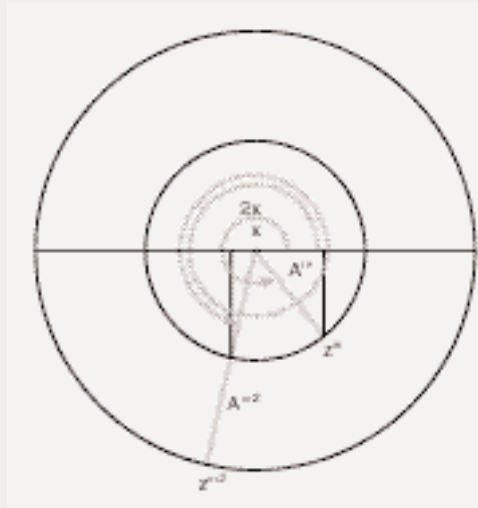

we showed in Part I. In Figure 11, the same principle is illustrated with respect to cubing. Here the angle  $x$  is tripled to  $3x$ , and the length  $A$  is cubed to  $A^3$ . In this case, the smaller circle maps three times onto the larger, “cubed” circle. And so on for the higher powers. The fourth power maps the smaller circle four times onto the larger. The fifth power, five times, and so forth.

This gives a general principle that determines all algebraic powers. From this standpoint, all powers are reflected by the same action. The only thing that changes with each power, is the number of times that action occurs. Thus, each power is distinguished from the others, not by a particular magnitude, but by a topological characteristic.

In his doctoral dissertation, Gauss used this principle to generate surfaces that expressed the essential characteristic of powers in an even more fundamental way. Each rotation and extension produced a characteristic right triangle. The vertical leg of that triangle is the *sine*, and the horizontal leg of that triangle is the *cosine* [SEE Figure 12]. There is a cyclical relationship between the sine and cosine, which is a function of the angle of rotation. When the angle is  $0$ , the sine is  $0$ , and the cosine is  $1$ . When the angle is  $90^\circ$ , the sine is  $1$ , and the cosine is  $0$ . Looking at this relationship for an entire rotation, the sine goes from  $0$ , to  $1$ , to  $0$ , to  $-1$ , and back to  $0$ ; while the cosine goes from  $1$ , to  $0$ , to  $-1$ , to  $0$ , and back to  $1$  [SEE Figure 13].

In Figure 13, as  $z$  moves from  $0$  to  $90^\circ$ , the sine of the angle varies from  $0$  to  $1$ ; but at the same time, the angle for  $z^2$  goes from  $0$  to  $180^\circ$ , and the sine of  $z^2$  varies from  $0$  to  $1$ , and back to  $0$ . Then, as  $z$  moves from  $90^\circ$  to  $180^\circ$ , the sine varies from  $1$  back to  $0$ , but the angle for  $z^2$  has moved from  $180^\circ$  to  $360^\circ$ , and its sine has varied from  $0$ , to  $-1$ , to  $0$ . Thus, in one half rotation for  $z$ , the sine of  $z^2$  has varied from  $0$ , to  $1$ , to  $0$ , to  $-1$ , to  $0$ .

In his doctoral dissertation, Gauss represented this complex of actions as a surface [SEE Figures 14, 15, and 16, and inside back cover, this issue]. Each point on the surface is determined such that its height above the flat plane, is equal to the distance from the center, times the sine of the angle of rotation, as that angle is increased by the effect of the power. In other words, the *power* of any point in the flat plane, is represented by the height of the surface above that point. Thus, as the numbers on the flat surface move outward from the center, the surface grows higher according to the power. At the same time, as the numbers rotate around the center, the sine will pass from positive to negative. Since the numbers on the surface are the powers of the numbers on the flat plane, the number of times the sine will change from positive to negative, depends on how much the power multiplies the angle (double for square powers, triple for cubics, etc.). Therefore, each surface will have as many “humps” as the equation has dimensions.

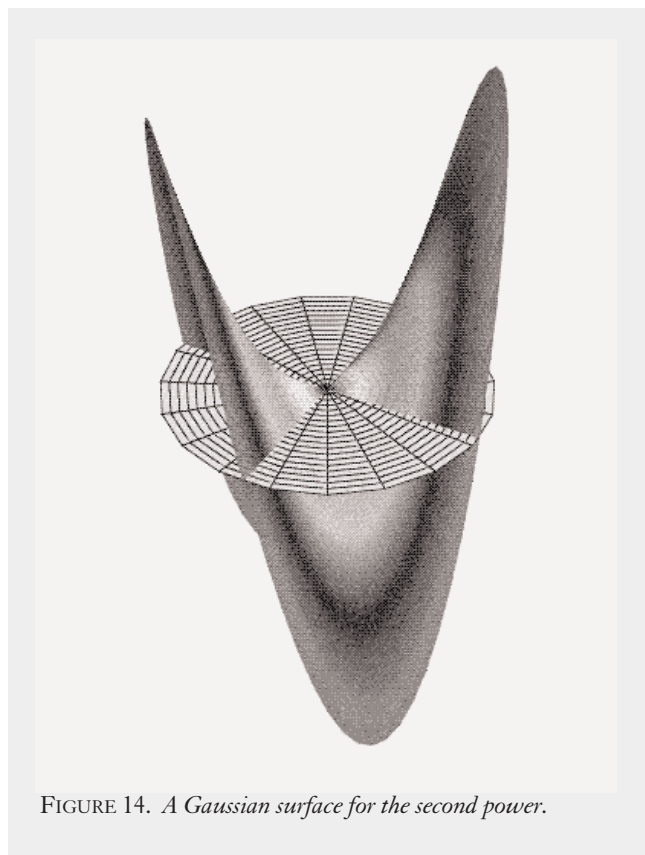

FIGURE 14. A Gaussian surface for the second power.

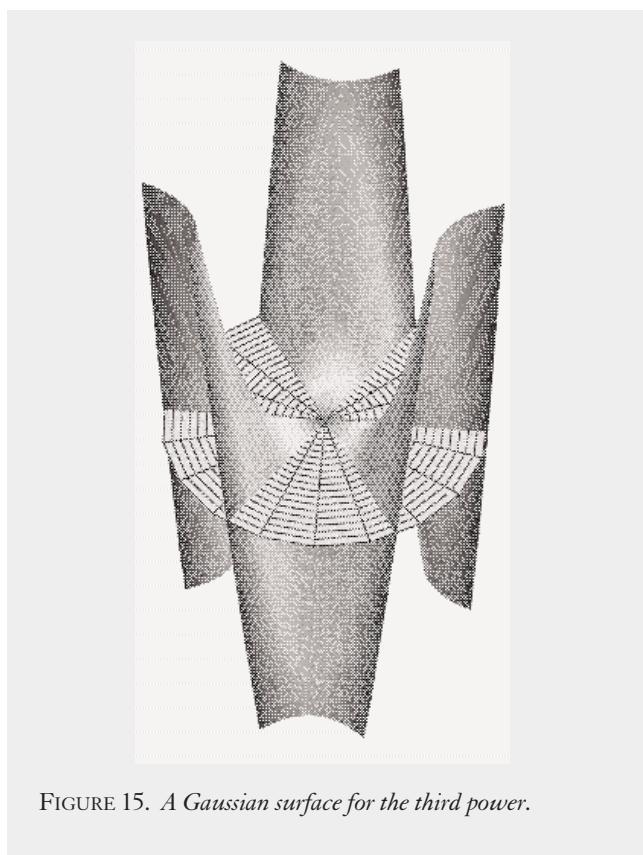

FIGURE 15. A Gaussian surface for the third power.

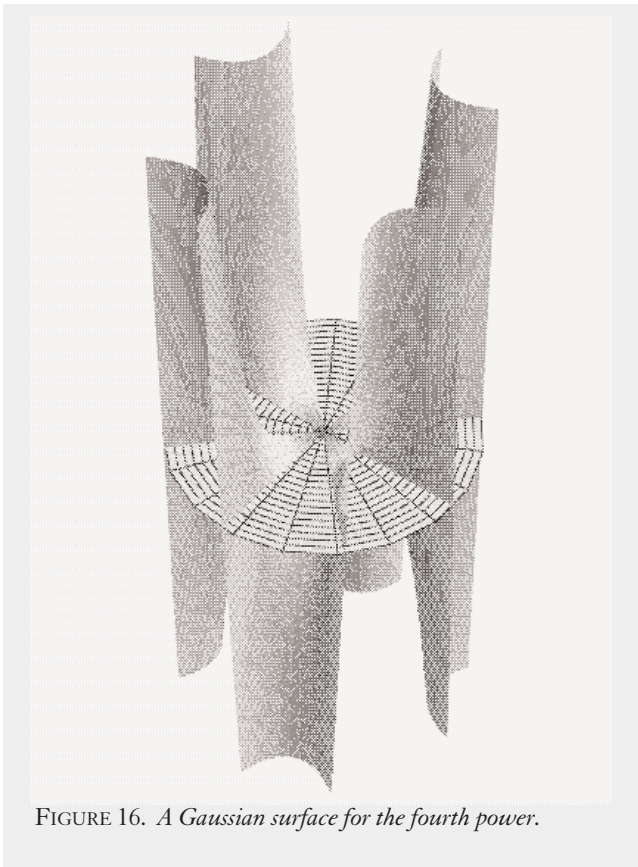

FIGURE 16. *A Gaussian surface for the fourth power.*

Consequently, a quadratic equation will have two “humps” up, and two “humps” down [Figure 14]. A cubic equation will have three “humps” up, and three “humps” down [Figure 15]. A fourth-degree equation will have four “humps” in each direction [Figure 16]; and so on.

Gauss specified the construction of two surfaces for each algebraic equation, one based on the variations of the sine and the other based on the variations of the cosine [SEE Figure 17]. Each of these surfaces will define definite curves on the flat plane intersected by the surfaces [SEE Figure 18]. The number of curves will depend on the number of “humps,” which in turn depend on the highest power.

Since sine and cosine surfaces are rotated  $90^\circ$  to each other, the curves on the flat plane will intersect each other, and the number of intersections will correspond to the number of powers. If the flat plane is considered to be zero, these intersections will correspond to the solutions, or “roots” of the equation. This proves that an algebraic equation has as many roots as its highest power [Figure 18].

### The Principle of Powers

Step back and look at this work. These surfaces were produced, not from visible squares or cubes, but from the general principle of squaring, cubing, and higher powers.

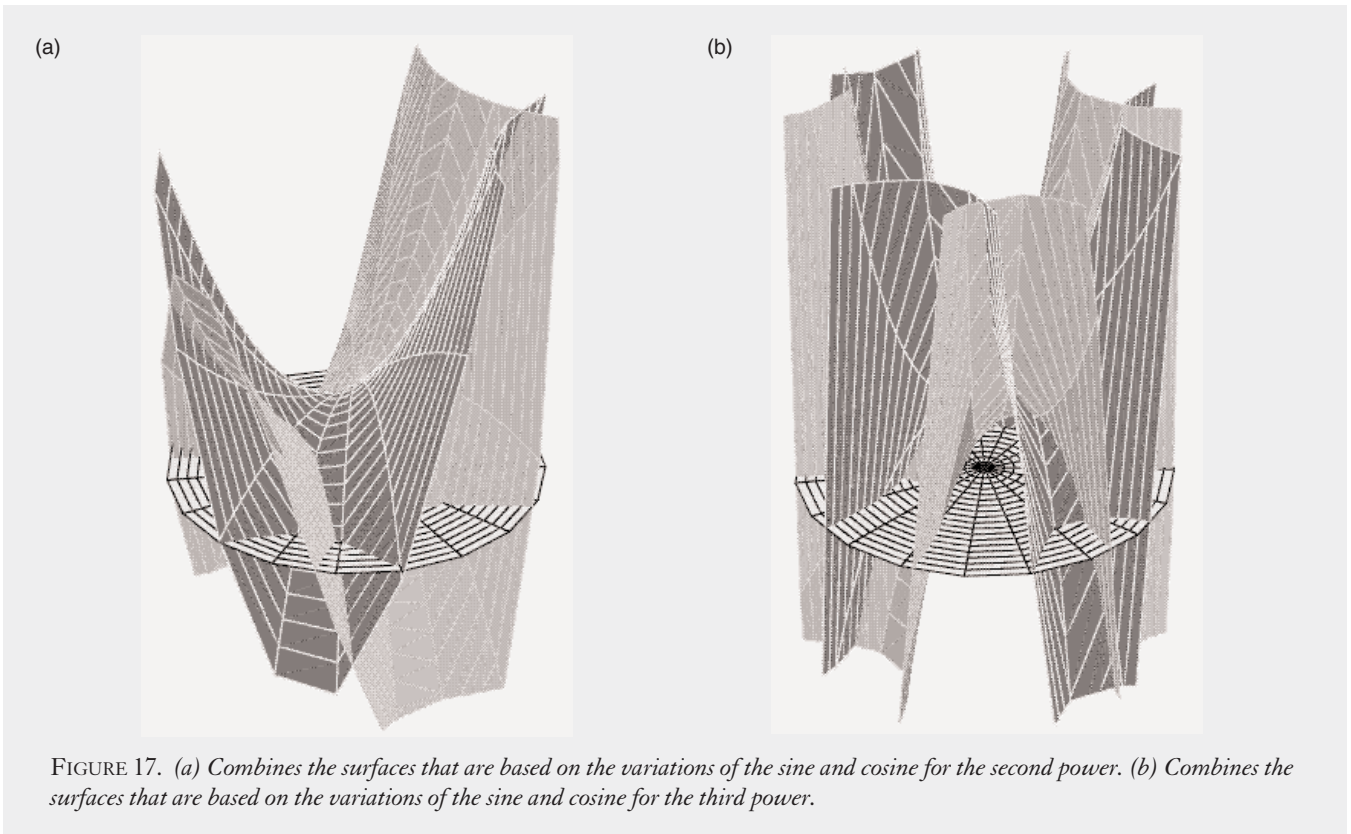
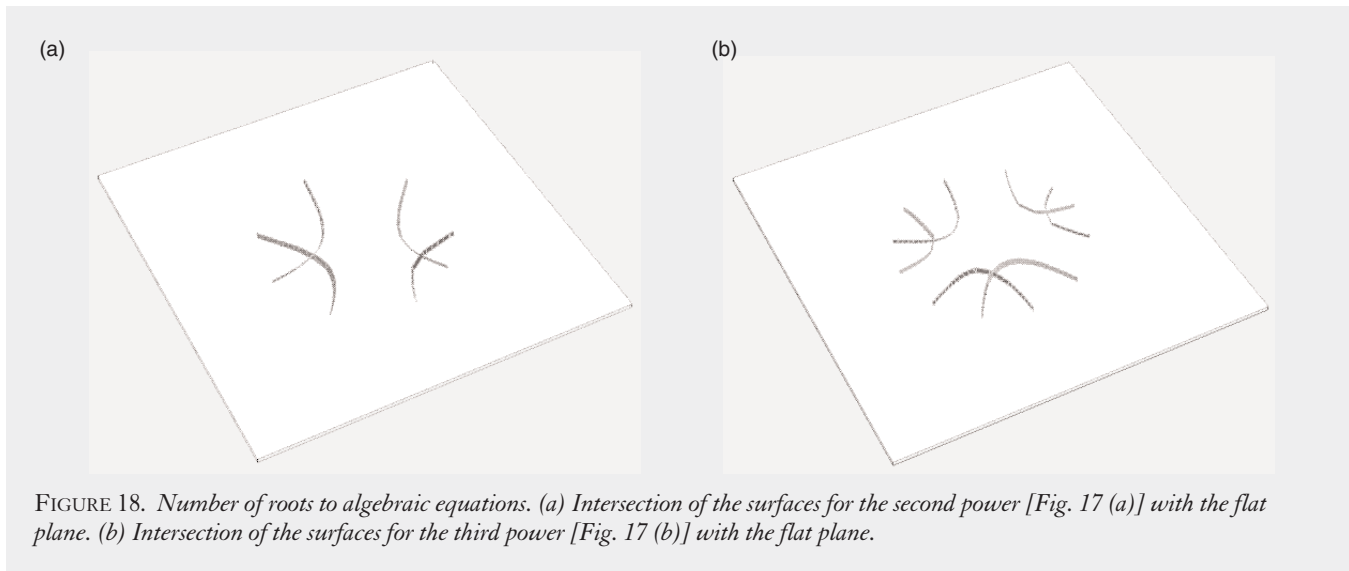

FIGURE 17. (a) *Combines the surfaces that are based on the variations of the sine and cosine for the second power.* (b) *Combines the surfaces that are based on the variations of the sine and cosine for the third power.*



They represent, metaphorically, a principle that manifests itself physically, but cannot be seen. By projecting this principle—the general form of Plato’s *powers*—onto these complex surfaces, Gauss has brought the invisible into view, and made intelligible what is incomprehensible in the superficial world of algebraic formalism.

The effort to make intelligible the implications of the complex domain, was a focus for Gauss throughout his life. Writing to his friend Hansen on Dec. 11, 1825, Gauss said:

These investigations lead deeply into many others, I would even say, into the Metaphysics of the theory of space, and it is only with great difficulty that I can tear myself away from the results that spring from it, as, for example, the true metaphysics of negative and complex numbers. The true sense of the square root of -1 stands before my mind fully alive, but it becomes very difficult to put it in words; I am always only able to give a vague image that floats in the air.

It was here, that Bernhard Riemann began.

#### AFTERWORD

## Dialogue on the Fundamentals of Sound Education Policy

*Lyndon H. LaRouche, Jr. responds to a question on education reform sent to his Presidential campaign website.*

\* \* \*

Sometimes, even often, perhaps, the best way to attack an apparently nebulous subject-matter, such as today’s animal-training of students to appear to pass standardized designs of tests, is to flank the apparent issue, in order to get to the deeper, underlying issues which the apparent subject-matter merely symptomizes. I respond accordingly.

There is a growing number of persons, chiefly university students, who have become active in our work here,

and who represent special educational needs and concerns. These concerns include the insult of being subjected to virtually information-packed, but knowledge-free, and very high-priced education. More significant, is being deprived of access to the kind of knowledge to which they ought to have access as a matter of right. In various sessions in which they have tackled me in concentrations of one to several score individuals each, many of the topics posed add up to a challenge to me: “What are you going to do to give us a real education?” There is nothing unjust in that demand; I welcome it. However, delivering the product in a relatively short time, is a bit of a challenge.

I have supplied some extensive answers to that sort of question, but let me reply to your question by focussing upon what I have chosen as the cutting-edge of the package I have presented.

In the same period he was completing his *Disquisitiones Arithmeticae*, young Carl Gauss presented the first of his several presentations of his discovery of the fundamental theorem of algebra. In the first of these he detailed the fact that his discovery of the definition and deeper meaning of the complex domain provided a comprehensive refutation of the anti-Leibniz doctrine of “imaginary numbers” which had been circulated by Euler and Lagrange. Gauss, working from the standpoint of the most creative of his Göttingen professors, Kästner, successfully attacked the problem of showing the folly of Euler’s and Lagrange’s work, and gave us both the modern notion of the complex domain, as well as laying the basis for the integration of the contributions of both Gauss and Dirichlet under the umbrella of Riemann’s original development of a true anti-Euclidean (rather than merely non-Euclidean) geometry.

In his later writings on the subject of the fundamental theorem, Gauss was usually far more cautious about attacking the reductionist school of Euler, Lagrange, and Cauchy, until near the end of his life, when he elected to make reference to his youthful discoveries of anti-Euclidean geometry. Therefore, it is indispensable to read his later writings on the subject of the fundamental theorem in light of the first. From that point of view, the consistency of his underlying argument in all cases, is clear, and also the connection which Riemann cites in his own habilitation dissertation is also clarified.

## The Central Issue of Method

Now, on background. Over the past decades of arguing, teaching, and writing on the subject of scientific method, I have struggled to devise the optimal pedagogy for providing students and others with a more concise set of cognitive exercises by means of which they might come to grips with the central issue of method more quickly. I have included the work of Plato and his followers in his Academy, through Eratosthenes, and moderns such as Brunelleschi, Cusa, Pacioli, Leonardo, Kepler, Fermat, Huyghens, Bernoulli, and Leibniz, among others of that same anti-reductionist current in science. All that I can see in retrospect as sound pedagogy, but not yet adequate for the needs of the broad range of specialist interest of the young people to whom

I have referred. I needed something still more concise, which would establish the crucial working-point at issue in the most efficient way, an approach which would meet the needs of such a wide range of students and the like. My recent decision, developed in concert with a team of my collaborators on this specific matter, has been to pivot an approach to a general policy for secondary and university undergraduate education in physical science, on the case of Gauss’s first presentation of his fundamental theorem.

Göttingen’s Leipzig-rooted Abraham Kästner, was a universal genius, the leading defender of the work of Leibniz and J.S. Bach, and a key figure in that all-sided development of the German Classic typified by Kästner’s own Lessing, Lessing’s collaborator against Euler *et al.*, Moses Mendelssohn, and such followers of theirs as Goethe, Schiller, and of Wolfgang Mozart, Beethoven, Schubert, the Humboldt brothers, and Gerhard Scharnhorst. On account of his genius, Kästner was defamed by the reductionist circles of Euler, Lagrange, Laplace, Cauchy, Poisson, *et al.*, to such a degree that plainly fraudulent libels against him became almost an article of religious faith among reductionists even in his lifetime, down to modern scholars who pass on those frauds as eternal verities to the present time. Among the crucial contributions of Kästner to all subsequent physical science, was his originating the notion of an explicitly anti-Euclidean conception of mathematics to such followers as his student the young Carl Gauss. Gauss’s first publication of his own discovery of the fundamental theorem of algebra, makes all of these connections and their presently continued leading relevance for science clear.

## Platonic vs. Reductionist Traditions

This shift in my tactics has the following crucial features.

The crucial issue of science and science education in European civilization, from the time of Pythagoras and Plato, until the present, has been the division between the Platonic and reductionist traditions. The former as typified for modern science by Cusa’s original definition of modern experimental principles, and such followers of Cusa as Pacioli, Leonardo, Gilbert, Kepler, Fermat, *et al.* The reductionists, typified by the Aristoteleans (such as Ptolemy, Copernicus, and Brahe), the empiricists (Sarpi, Galileo, *et al.*, through Euler and Lagrange, and beyond), the “critical school” of neo-Aristotelean empiricists (Kant, Hegel), the positivists, and the existentialists. This division is otherwise expressed as the conflict between reductionism in the

guise of the effort to derive physics from “ivory tower” mathematics, as opposed to the methods of (for example) Kepler, Leibniz, Gauss, and Riemann, to derive mathematics, as a tool of physical science, from experimental physics.

The pedagogical challenge which the students’ demands presented to me and to such collaborators in this as Dr. Jonathan Tennenbaum and Mr. Bruce Director, has been to express these issues in the most concise, experimentally grounded way. All of Gauss’s principal work points in the needed direction. The cornerstone of all Gauss’s greatest contributions to physical science and mathematics is expressed by the science-historical issues embedded in Gauss’s first presentation of his discovery of the fundamental theorem of algebra.

All reductionist methods in consistent mathematical practice depend upon the assumption of the existence of certain kinds of definitions, axioms, and postulates, which are taught as “self-evident,” a claim chiefly premised on the assumption that they are derived from the essential nature of blind faith in sense-certainty itself. For as far back in the history of this matter as we know it today, the only coherent form of contrary method is that associated with the term “the method of hypothesis,” as that method is best typified in the most general way by the collection of Plato’s Socratic dialogues. The cases of the *Meno*, the *Theatetus*, and the *Timaeus*, most neatly typify those issues of method as they pertain immediately to matters of the relationship between mathematics and physical science. The setting forth of the principles of an experimental scientific method based upon that method of hypothesis, was introduced by Nicolaus of Cusa, in a series of writings beginning with his *De Docta Ignorantia*. The modern Platonic current in physical science and mathematics, is derived axiomatically from the reading of Platonic method introduced by Cusa. The first successful attempt at a comprehensive mathematical physics based upon these principles of a method of physical science, is the work of Kepler.

From the beginning, as since the dialogues of Plato, scientific method has been premised upon the demonstration that the formalist interpretation of reality breaks down, fatally, when the use of that interpretation is confronted by certain empirically well-defined ontological paradoxes, as typified by the case of the original discovery of universal gravitation by Kepler, as reported in his 1609 *The New Astronomy*. The only true solution to such paradoxes occurs in the form of the generation of an hypothesis, an hypothesis of the quality which overturns some existing definitions, axioms, and postulates, and also introduces hypothetical new universal principles. The

validation of such hypotheses, by appropriately exhaustive experimental methods, establishes such an hypothesis as what is to be recognized as either a universal physical principle, or the equivalent (as in the case of J.S. Bach’s discovery and development of the principles of composition of well-tempered counterpoint).

## The Geometry of the Complex Domain

Gauss’s devastating refutation of Euler’s and Lagrange’s misconception of “imaginary numbers,” and the introduction of the notion of the physical efficiency of the geometry of the complex domain, is the foundation of all defensible conceptions in modern mathematical physics. Here lies the pivot of my proposed general use of this case of Gauss’s refutation of Euler and Lagrange, as a cornerstone of a new curriculum for secondary and university undergraduate students.

Summarily, Gauss demonstrated not only that arithmetic is not competently derived axiomatically from the notion of the so-called counting numbers, but that the proof of the existence of the complex domain within the number-domain, showed two things of crucial importance for all scientific method thereafter. These complex variables are not merely powers, in the sense that quadratic and cubic functions define powers distinct from simple linearity. They represent a replacement for the linear notions of dimensionality, by a general notion of extended magnitudes of physical space-time, as Riemann generalized this from, chiefly, the standpoints of both Gauss and Dirichlet, in his habilitation dissertation.

The elementary character of that theorem of Gauss, so situated, destroys the ivory-tower axioms of Euler *et al.* in an elementary way, from inside arithmetic itself. It also provides a standard of reference for the use of the term “truth,” as distinct from mere opinion, within mathematics and physical science, and also within the domain of social relations. Those goals are achieved only on the condition that the student works through Gauss’s own cognitive experience, both in making the discovery and in refuting reductionism generically. It is the inner, cognitive sense of “I know,” rather than “I have been taught to believe,” which must become the clearly understood principle of a revived policy of a universalized Classical humanist education.

Once a dedicated student achieves the inner cognitive sense of “I know this,” he, or she has gained a benchmark against which to measure many other things.

—Lyndon H. LaRouche, Jr.  
April 12, 2002